

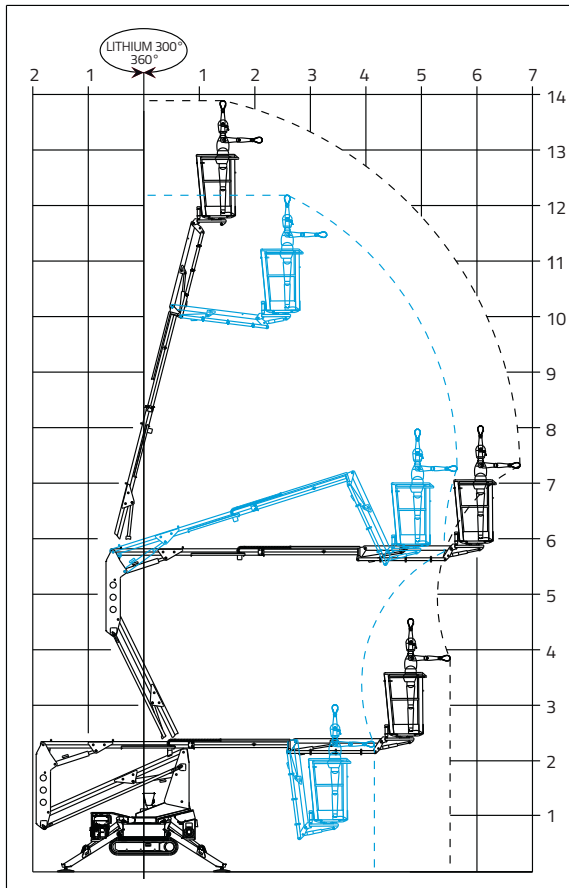

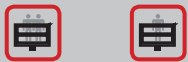

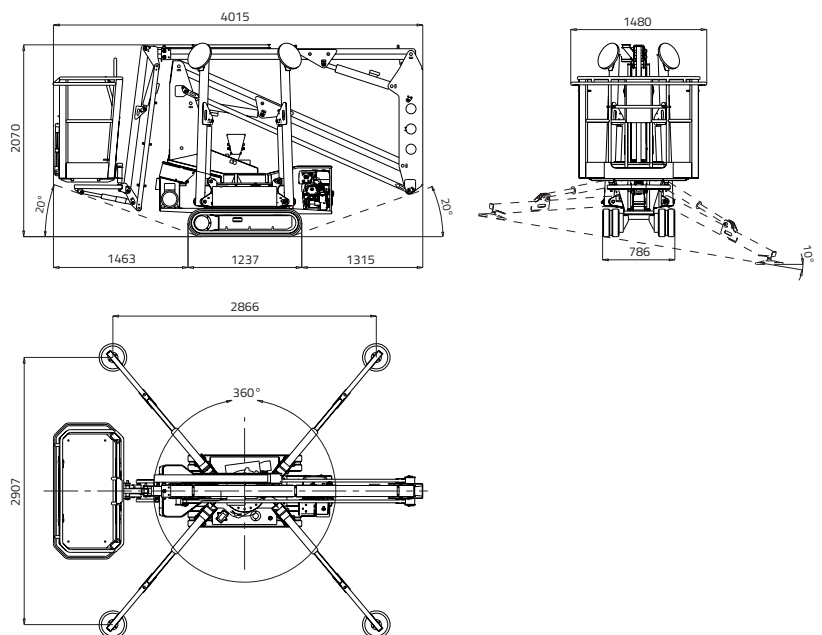

LL14.72







PORTATA 120 KG
(1 persona 80 kg + attrezzatura 40 kg)
PORTATA 200 KG
(2 persone 80x2=160 kg + attrezzatura 40 kg)



	12,25 m	13,90 m
	5,92 m	6,76 m
	4,01 m	
	3,79 m	
	2,07 m	

	1.335 x 690 x h 1.100 mm
	16° / 28,7%
	786 mm
	1200 daN - 1,7 daN/cm ²
	2907 x 2866 mm

	Stabiliz. e destabiliz. automatica IIIS di serie
	Filocomando
	GPRS-GPS
	R.A.H.M.

 Pacco batterie al litio
4,8 kWh
Opzionale



MOTORE BENZINA

Marca HONDA
 Tipo GX270 / GX390
 Cilindri e cilindrata monocilindrico
 270 cm³ / 389 cm³
 Potenza lorda max
 8,4 HP - 6,3 kW @ 3600 rpm (GX270)
 11,7HP - 8,7 kW @ 3600 rpm (GX390)
 Avviamento elettrico 12 volt

MOTORE DIESEL

Marca HATZ
 Tipo 1B30 - HD Autorev
 Cilindri e cilindrata monocilindrico
 347 cm³
 Potenza lorda max
 7,3 HP - 5,4 kW @ 3600 rpm
 Avviamento elettrico 12 volt

SISTEMA LITHIUM-ION

Pacco batterie al litio 4,8 kWh
 Caricabatterie a bordo
 220V 50Hz o 110V 50Hz
 Autonomia di lavoro 4-5 h
 Tempo di ricarica a batterie completamente
 scariche 4 h (indicativo)
 Tempo di ricarica all'80% da batterie com-
 pletamente scariche 2 h (indicativo)

MOTORE ELETTRICO

Standard 230V / 50 Hz - 2,2 kW
 Optional 110V / 50 Hz - 2,2 kW

CINGOLATURA

Tendingolo a grasso
 Rulli per lato 3 + slitta

Velocità di traslazione:

- motore benzina 1,3 - 2,6 km/h
 - motore diesel 1,5 - 3 km/h
 - motore lithium 1,1 - 2,1 km/h

PESO MACCHINA motore benzina/diesel 1398 kg
 PESO MACCHINA motore lithium 1490 kg

VELOCITÀ MAX VENTO 12,5 m/s